

Heavy Duty 4 Bar Hinges

22" & 28" Eurogroove
Inline & Offset
Projection

Optimum Performance Tested to Last

- Tested and Approved to FGIA AAMA 904-21
- Tested and Approved to BBA Certification
- Manufactured from high grade Austenitic Stainless Steel for enhanced corrosion resistance. Tested to Grade 5 (480 hours) exposure in accordance with BS EN 1670:2007.

Note: For larger or heavier sashes, all sash fixings should pick up reinforcement to ensure consistent performance.



Recommended Maximum Window Weights and Vent Sizes

	Product	Application	Overall Length	Opening Angle	Max. Weight	Max. Height
PROJECTION	HD22 SB EUROGROOVE 304	INLINE	22.33" [567.3mm]	20° or 40°	220lbs [100kg] @ 20° 176lbs [80kg] @ 40°	59" [1500mm]
	HD22 SB EUROGROOVE OS 304	OFFSET	22.37" [568.3mm]			
	HD28 EUROGROOVE 304	INLINE	27.89" [708.5 mm]	20°	220lbs [100kg] @ 20°	87" [2200mm]
	HD28 EUROGROOVE OS 304	OFFSET	27.93" [709.5 mm]			

Available in both Architectural and Loose Rivet Tensions

Fixing Hole Details

Product	Application	A	B	C	D	E	F	G	H	I	J	K	L
HD22 SB EUROGROOVE 304	INLINE	1.42" [36.0]	9.08" [230.7]	12.70" [322.6]	19.77" [502.1]	22.00" [558.8]	1.39" [35.3]	1.93" [49.0]	-	3.94" [100.0]	9.85" [250.2]	14.66" [372.5]	15.16" [385.0]
HD22 SB EUROGROOVE OS 304	OFFSET	1.46" [37.0]	9.12" [231.7]	12.74" [323.6]	19.81" [503.1]	22.04" [559.8]	1.43" [36.3]	1.97" [50.0]	-	3.98" [101.0]	9.89" [251.2]	14.70" [373.5]	15.20" [386.0]
HD28 EUROGROOVE 304	INLINE	1.42" [36.0]	9.27" [235.0]	10.79" [274.0]	23.84" [605.5]	27.58" [700.5]	2.05" [52.0]	2.64" [67.0]	3.90" [99.0]	4.92" [125.0]	8.01" [203.5]	13.38" [340.0]	18.74" [476.0]
HD28 EUROGROOVE OS 304	OFFSET	1.46" [37.0]	9.31" [236.0]	10.83" [275.0]	23.88" [606.5]	27.62" [701.5]	2.09" [53.0]	2.68" [68.0]	3.94" [100.0]	4.96" [126.0]	8.05" [204.5]	13.42" [341.0]	18.78" [477.0]

Inline

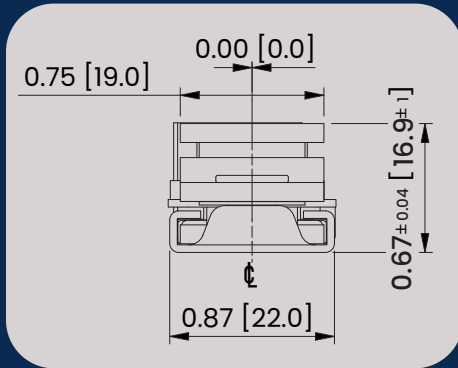

Offset

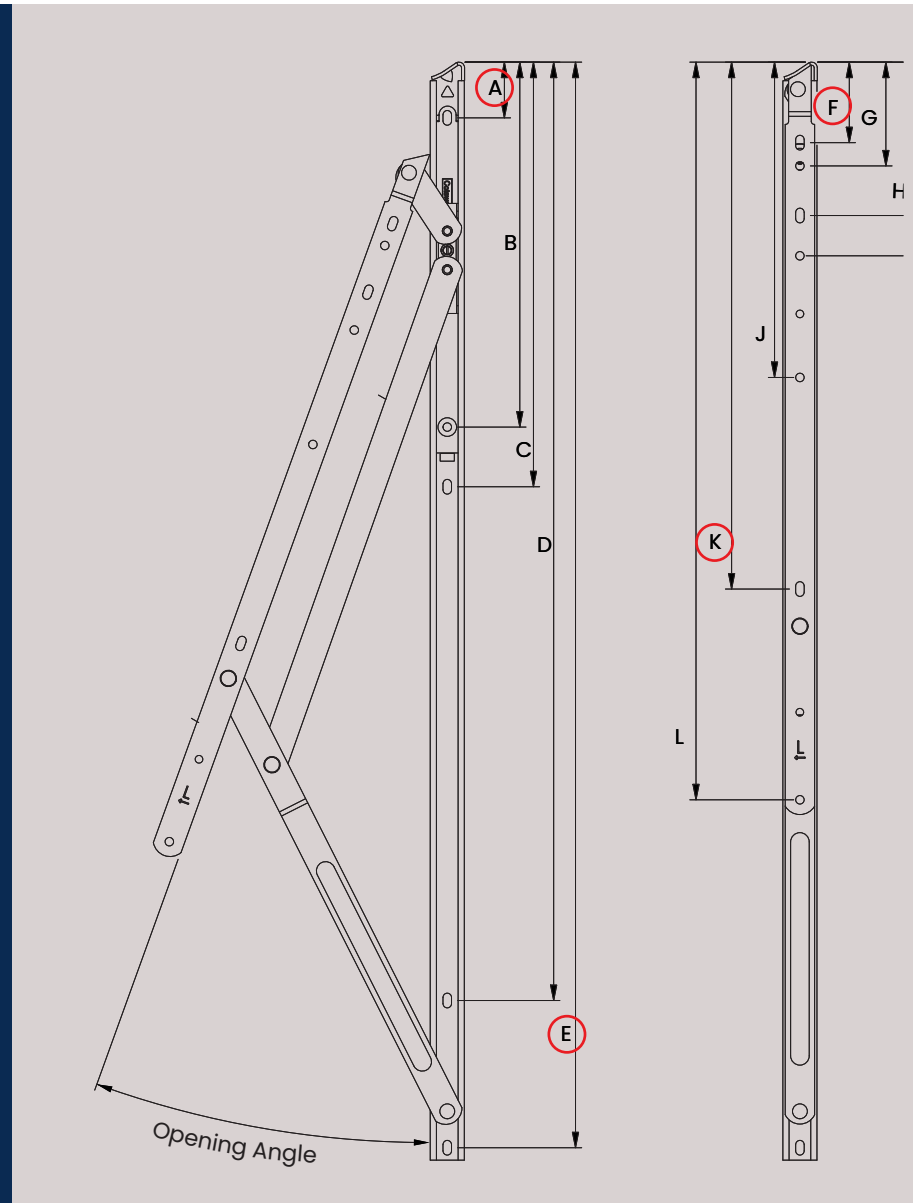
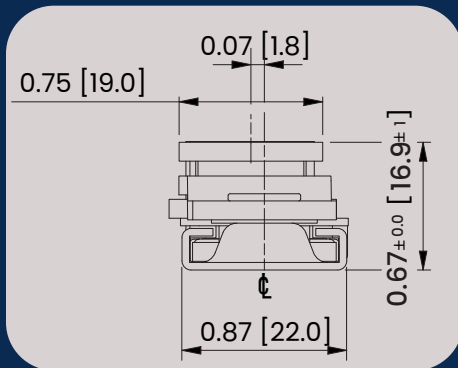

Note: All of the information shown on this data sheet was correct at the time of issue. All information however is subject to change and therefore it is advisable to check with Cotswold Architectural Products to ensure that you have the latest issue level.