

Heavy Duty 4 Bar Hinges

10" & 16" Eurogroove
Inline & Offset

Projection & Casement

Optimum Performance
Tested to Last

- Tested and Approved to FGIA AAMA 904-21
- Tested and Approved to BBA Certification
- Manufactured from high grade Austenitic Stainless Steel for enhanced corrosion resistance. Tested to Grade 5 (480 hours) exposure in accordance with BS EN 1670:2007.

Note: For larger or heavier sashes, all sash fixings should pick up reinforcement to ensure consistent performance.



Recommended Maximum Window Weights and Vent Sizes

	Product	Application	Overall Length	Opening Angle	Max. Weight	Max. Height
PROJECTION	HD10 R EUROGROOVE 304	INLINE	10.35" [263.0mm]	50° or 84°	110lbs [50kg] @ 50° 88lbs [40kg] @ 84°	26" [660.4mm]
	HD10 R EUROGROOVE OS 304	OFFSET	10.39" [264.0mm]			
	HD16 R EUROGROOVE 304	INLINE	16.38" [416 mm]	30°, 50° or 84°	220lbs [100kg] @ 30° 132lbs [60kg] @ 50° 110lbs [50kg] @ 90°	32" [812.8mm]
	HD16 R EUROGROOVE OS 304	OFFSET	16.42" [417 mm]			

	Product	Application	Overall Length	Opening Angle	Max. Weight	Max. Width
CASEMENT	HD10 R EUROGROOVE 304	INLINE	10.35" [263.0mm]	50° or 84°	76lbs [34.5kg]	26" [660.4mm]
	HD10 R EUROGROOVE OS 304	OFFSET	10.39" [264.0mm]			
	HD16 R EUROGROOVE 304	INLINE	16.38" [416mm]	30°, 50° or 84°	95.5lbs [43kg]	30" [762mm]
	HD16 R EUROGROOVE OS 304	OFFSET	16.42" [417mm]			

Available in both Architectural and Loose Rivet Tensions

Fixing Hole Details

Product	Application	A	B	C	D	E	F	G	H	I	J
HD10 R EUROGROOVE 304	INLINE	1.44" [36.5]	-	6.65" [169.0]	8.44" [214.5]	10.02" [254.5]	1.36" [34.5]	1.91" [48.5]	-	7.40" [188.0]	8.35" [212.0]
HD10 R EUROGROOVE OS 304	OFFSET	1.47" [37.5]	-	6.69" [170.0]	8.48" [215.5]	10.06" [255.5]	1.40" [35.5]	1.95" [49.5]	-	7.44" [189.0]	8.38" [212.7]
HD16 R EUROGROOVE 304	INLINE	1.42" [36.0]	7.09" [180.0]	9.01" [229.0]	13.41" [340.5]	16.04" [407.5]	1.38" [35.0]	1.93" [49.0]	3.94" [100.0]	10.87" [276.0]	11.36" [288.5]
HD16 R EUROGROOVE OS 304	OFFSET	1.46" [37.0]	7.12" [181.0]	9.05" [230.0]	13.44" [341.5]	16.07" [408.2]	1.42" [36.0]	1.97" [50.0]	3.98" [101.0]	10.90" [277.0]	11.40" [289.5]

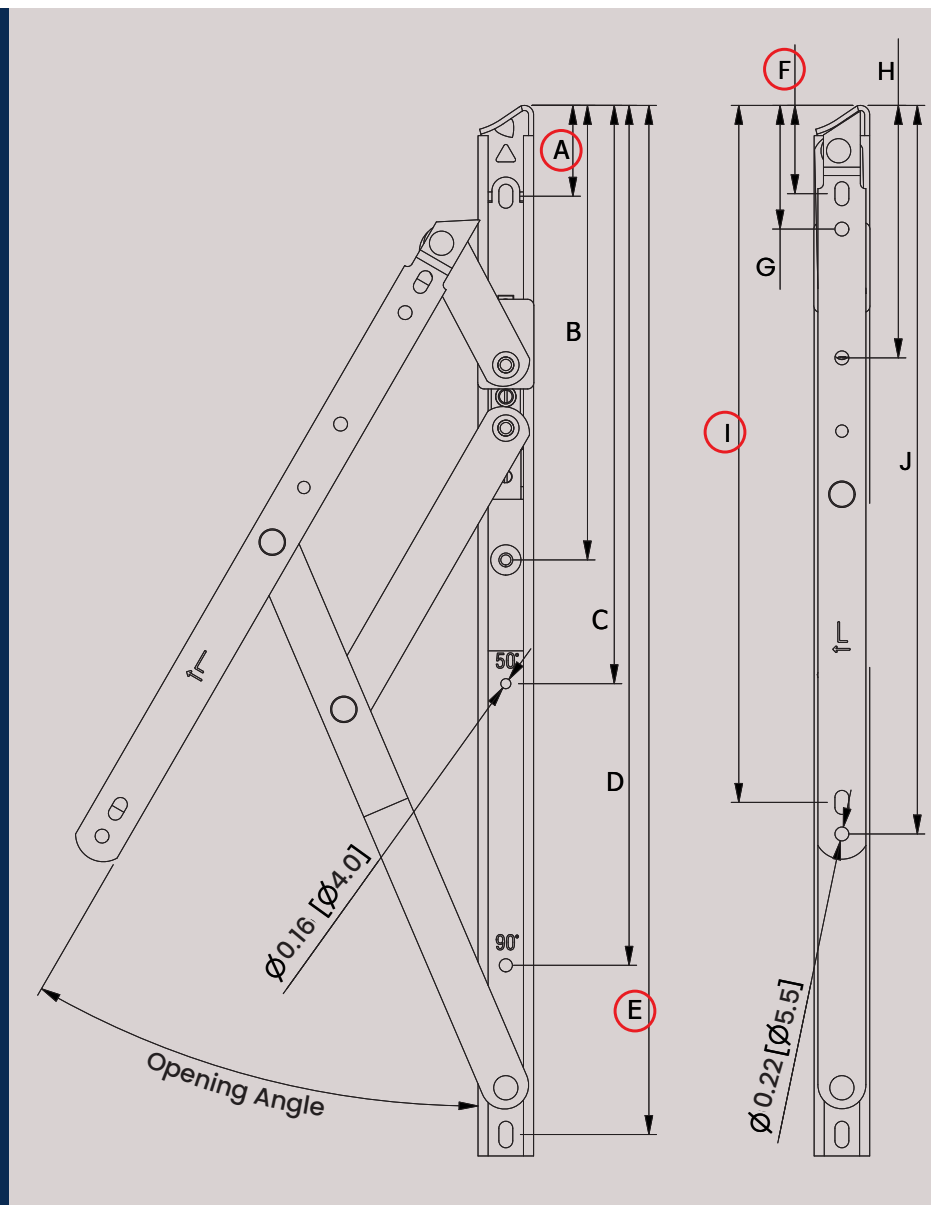
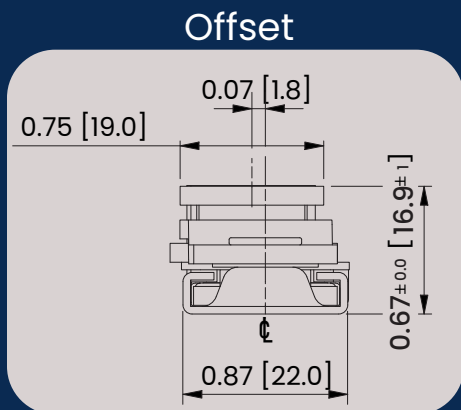
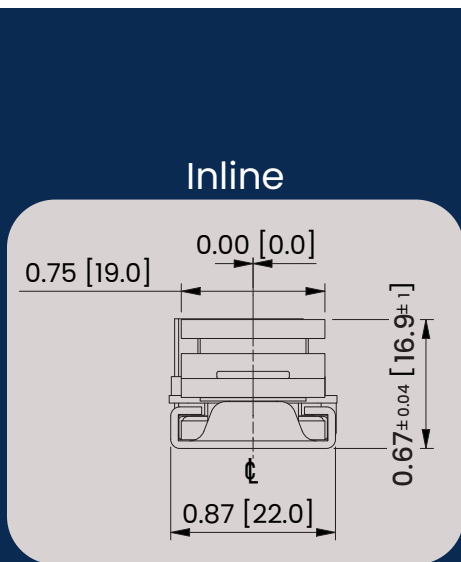

Note: All of the information shown on this data sheet was correct at the time of issue. All information however is subject to change and therefore it is advisable to check with Cotswold Architectural Products to ensure that you have the latest issue level.